

Router 6600/6600 Pro

LARGE FORMAT, HIGH SPEED FLOOR-STANDING ROUTER

ALSO AVAILABLE:
ROUTER 6600 ATC
SEE PAGES 14-15



QUALITY, PRECISION,
MAINTENANCE FREE
ROUTING

For full details - See page 9

Router 6600 shown with optional computer support extension and integrated Dust Pro 100 (PC not included)

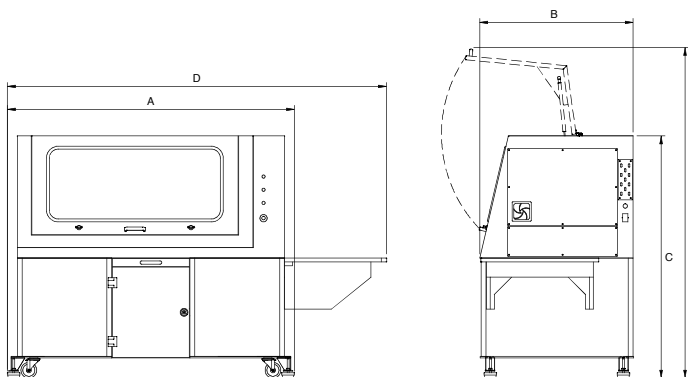

Machine Dimensions.

A large format, high speed Router, complete with built-in machine bench, offering large machining capacity (table size 1080 x 640mm) at an exceptional price. The Router 6600 / 6600 Pro is specifically designed for education and training and is ideal for cutting a range of resistant materials such as hard and soft wood, plastic, modelling foam, acrylic and prototyping material. In addition, the Router 6600 Pro can cut non-ferrous metals.



APPROVED

Ideal for use in conjunction with



Router 6600/6600 Pro

THE ROUTER 6600/6600 PRO COME AS STANDARD WITH:

- VR CNC Milling Operating Software (PC not included)
- QuickCAM 2D Design Software (1 seat)
- Universal Machine Bench
- Aluminium T Slot Table
- Outlet for Dust Extraction System
- Workholding Clamps
- Installation and Instruction Manuals
- USB Connection

OPTIONAL EQUIPMENT INCLUDES:

Large Format Vacuum Bed, Vacuum Pads, F1 in Schools Car Manufacturing Fixture, 4th Axis Programmable Rotary Fixture, 3D Scanning Attachment, Dust Extraction Unit, Computer Support Extension.



RECOMMENDED SYSTEM REQUIREMENTS

Please refer to page 25.

RECOMMENDED SOFTWARE PROGRAMS

All software necessary to control the Router 6600/ Router 6600 Pro is included. Also included is a seat of QuickCAM 2D Design - an easy to use 2D CAD package.

- 2D Designs: The VR Milling software can import DXF, DWG, EPS and Gerber files in addition to G & M code programs and as such will link with programs such as Techsoft 2D Design and CorelDraw.
- 3D Designs: To enable import of STL files from 3D design packages, QuickCAM Pro software is required (see pages 38 - 39).

MECHANICAL DETAILS	ROUTER 6600	ROUTER 6600 PRO
Machine Length (A)	1825mm - 71.85in	
Machine Depth (B)	985mm - 38.78in	
Machine Height (C)	1540mm - 60.63in	
Length with Optional PC Arm (D)	2410mm - 94.88in	
Height with Door Open (E)	2110mm - 83.07in	
Machine Weight	430kg - 947.99lb	
Table Size	1080 x 640mm - 42.52 x 25.20in	
Travel X Axis	1000mm - 39.37in	
Travel Y Axis	600mm - 23.62in	
Travel Z Axis	110mm - 4.33in	
Beam Clearance	148mm - 5.83in	
Max. Spindle Speed	29000 rpm	24000 rpm
Non-Ferrous Metal Cutting	No	Yes
Spindle Speed Control	No	Yes
Spindle Speed Override	No	Yes
Max. Feed Rate	5000mm/min - 196.85in/min	
Max. 3D Profiling	4500mm/min - 177.17in/min	
Spindle Motor 110V Supply	800W - 1.07HP	1.0kW - 1.34HP
Spindle Motor 230V Supply	1.0kW - 1.34HP	
Axes Motors	Stepper	
Power Requirements	Single Phase, 230V - 8A / 110V - 10A	
Frequency	50/60 Hz	